

A Class E Power Amplifier Design for Drain Modulation under a High PAPR WiMAX Signal

L. Cabria¹, P. M. Cabral², J. C. Pedro² and J. A. García¹

¹ Departamento Ingeniería de Comunicaciones, Universidad de Cantabria, 39005, Santander, SPAIN

² Instituto de Telecomunicações - Universidade de Aveiro, Campus Universitário de Santiago, 3810-193, Aveiro, PORTUGAL

Abstract — This paper describes the design of a class E power amplifier (PA) destined to be used as the final stage of a polar transmitter under IEEE 802.16e Mobile WiMAX signal excitation. Based on a 60 W GaN HEMT device, the load condition for optimum efficiency is set close to the maximum value of the power generating function, as defined in [1], for an OFDMA modulating signal. The possible impact of such average-based design on the AM profile is also put into consideration.

Index Terms — EER, efficiency, GaN HEMT, linearity, polar transmitter, power amplifier.

I. INTRODUCTION

Trying to find different perspectives to look into the linearity versus efficiency trade-off, nowadays, both the academic and industrial communities are focusing their attention in emerging transmitter architectures. Polar transmitters, based on Kahn envelope elimination and restoration (EER) concept [2], are one of the most promising solutions. In this topology, the phase modulated carrier is amplified by means of switched mode RF power amplifiers (class D⁻¹, E/E⁻¹ or F/F⁻¹), while the amplitude component is reinserted through the drain biasing as a high level amplitude modulation over the final stage (see Fig. 1). Therefore, unbeatable levels of linearity and efficiency are expected from these polar Tx's.

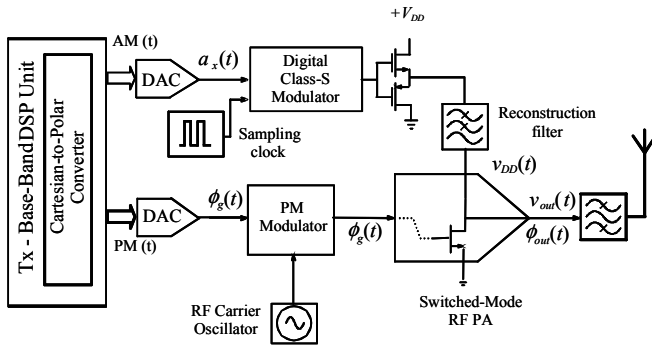

Fig. 1. System level representation of a wireless polar transmitter

However, there are a series of system, circuit and device level reasons that justify why this ideally linear and highly

efficient polar design cannot be met in practice [3]. The nonlinear behavior can be enhanced applying digital predistortion techniques (DPD) [4] to meet the spectral mask specifications, whereas the power added efficiency (PAE) depends on achieving high efficiency in both switch-mode PA and envelope amplifier. In order to achieve high average PAE, the design of the PA is conditioned to the probability density function (pdf) of the envelope signal to be transmitted [1].

Although still faraway from the conceptual Software Defined Radio (SDR) transmitter, the envelope amplifier, used in polar topologies, may be, in principle, frequency and modulation agnostic, leaving the hardware reconfiguration problems for the PM RF path.

II. CLASS E PA DESIGN FOR EER OPERATION

Switched mode RF power amplifiers are usually designed by setting an appropriate load impedance condition at the fundamental component, while also shaping the current and voltage waveforms through a correct control over higher harmonics. For an ideal class E amplifier, introduced by Nathan and Alan Sokal, in [5], the drain impedance must fit (1).

$$Z_d(f_0) \approx 0.28 / (2 \cdot \pi \cdot f_0 \cdot C_{out}) \cdot e^{(j \cdot 49^\circ)} \quad (1)$$

$$Z_d(k \cdot f_0) \approx \infty \text{ for } k > 1 \quad (2)$$

Taking into account the device output capacitance, C_{out} , variation with V_{ds} , maximum efficiency is usually obtained for a certain operating condition, degrading itself for lower or higher drain to source biasing values.

Under polar (EER) transmitter operation, the applied drain voltage excursion, $V_{dd}(t)$, should follow the amplitude component of the desired output signal, being the RF PA average efficiency figures related to the probability density function of the modulating signal. In this work, the procedure suggested in [1] has been followed, trying to optimize the polar transmitter output stage design under IEEE 802.16e Mobile WiMAX signal excitation, from an efficiency point of view.

A. GaN HEMT Class E PA

A transmission line class E topology [6], based on a 60 W GaN HEMT from Cree Inc., CGH35060, was selected.

In order to maximize efficiency, it is necessary to choose not only the adequate transmitter architecture or PA class, but also the appropriate transistor technology. The outstanding characteristics of GaN HEMT devices (high power density, high f_t , low input capacitance, manageable output capacitance and low ON-state resistance, R_{ON}) convert them into ideal solutions to implement switched mode PAs.

In this particular design, open-circuit terminations at second and third harmonics were implemented. Equation (1) was first employed as a starting point to estimate the optimum load at the frequency band center, although additional load refinements were performed through load-pull simulations in the search for highest PAE. The multiharmonic network at the output was conceived to cover the desired frequency range, the new 760-830 MHz professional communication band.

In Fig. 2, a photograph of the implemented amplifier is presented. As it can be seen, a dedicated biasing path was prepared for inserting the low frequency envelope signal. High Q capacitances and inductances have been employed in the prototype.

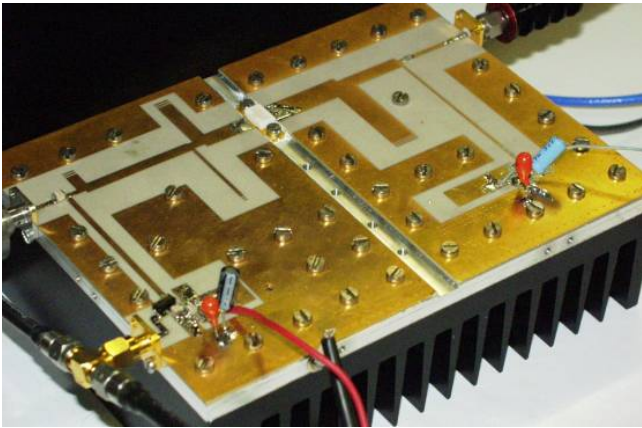

Fig. 2. Photograph of the implemented PA.

B. PA Behavior in the Desired Frequency Band

The PA has been characterized in the desired frequency band under a CW excitation signal and fixed drain biasing voltage ($V_{DD} = 32V$). In Fig. 3, the measured output power (P_{OUT}) and power added efficiency evolution as a function of frequency are shown. A P_{OUT} value slightly higher than 60 W is achieved at half-band, with a deviation always lower than 1 dB. Despite of a 10% PAE variation in the desired band, the minimum measured value is over 60%, a quite good global result. It would be even possible to readjust the output network to improve maximum efficiency, for applications with narrower frequency bands.

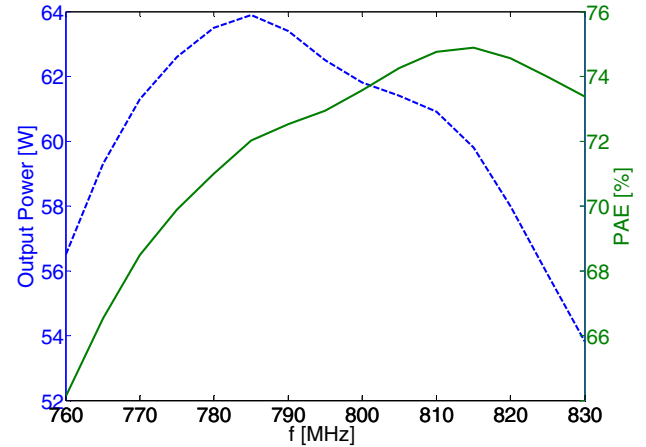

Fig. 3. Measured (--) output power (left) and (-) PAE (right) vs. frequency at an input power level of 25dBm.

B. Efficiency and Linearity Modulating Profiles

The power generating function [1], resulting from the Rayleigh pdf distribution of the OFDMA signal amplitude component, as well as the output power vs. V_{ds} profile of the saturated class E amplifier, are all plotted in Fig. 4. The average output power appears for a V_{dd} value close to 13 V, biasing condition at which the class E fundamental output impedance was selected in order to maximize efficiency.

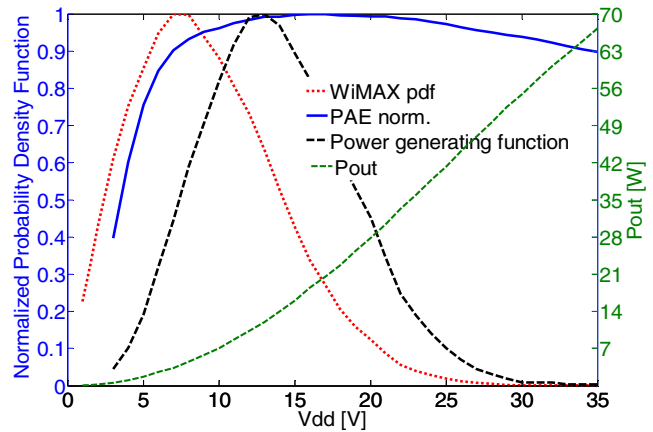

Fig. 4. Amplitude component pdf for a WiMAX signal, P_{out} , power generating function [1], and normalized PAE (to a maximum value of 79%) vs. V_{dd} .

The resulting AM modulating profile is shown in Fig. 5, together with the parasitic phase modulating characteristic. At high drain voltage values, and despite the high excitation level employed, both characteristics manifest a residual nonlinearity. This saturation has been proved to be related with the device leaving switched mode of operation and behaving as a controlled current-source [3], in this case,

probably, due to the inappropriate value of the load impedance seen from the drain side at such high V_{dd} excursions. In fact, a peak power amplifier design, with an optimum power added efficiency adjusted for $V_{dd(t)max}$, shows a nearly ideal linear modulating profile (except of course for the low voltage feedthrough effect).

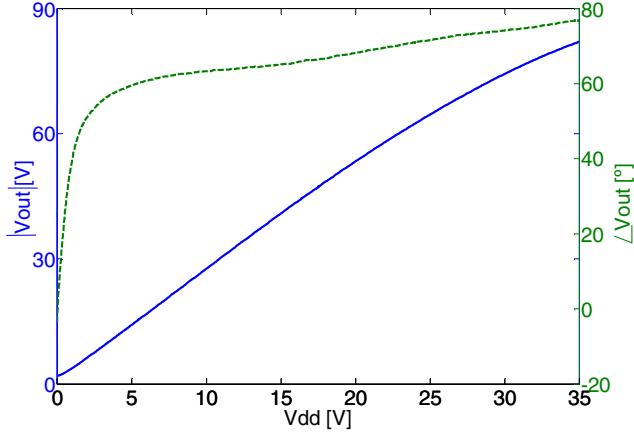

Fig. 5. (-) V_{dd} -to-AM and (--) V_{dd} -to-PM profiles.

III. PA CHARACTERIZATION IN POLAR TRANSMITTER (EER) OPERATION

In order to evaluate the linearity and average efficiency figures of the designed class E PA, the polar transmitter test set-up shown in Fig. 6 was implemented. After generating the amplitude and phase components employing Matlab, these are sent to two vector signal generators (Agilent Technologies E4438C) to obtain the baseband and RF signals, respectively. The output signal is captured with Agilent's 89600 vector signal analyzer, obtaining the response either in frequency or time domain.

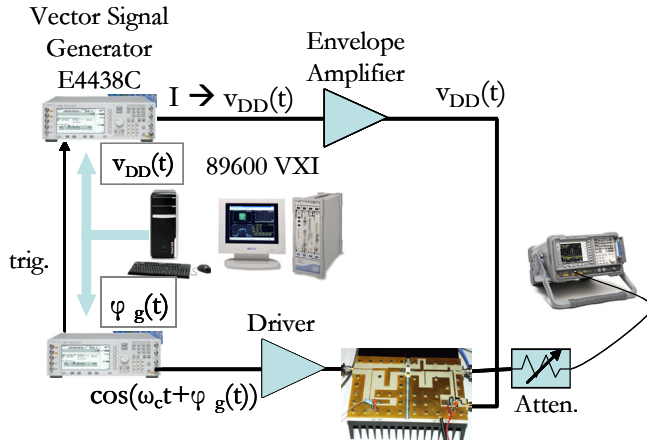

Fig. 6. Polar transmitter test set-up.

The envelope amplifier has to give response to the stringent requirements of the GaN HEMT PA to be modulated (peak drain current and voltage values of 3 A and 38 V respectively), while also offering enough bandwidth to avoid distortion generation [4]. Moreover, considering the maximum voltage provided by the E4438C I and Q rear output connectors (1 V), a high voltage gain was also needed. In this particular set up, two cascade non-inverse amplifiers were implemented, with the output stage based on the high slew-rate, high current and high voltage operational amplifier PA119 from Apex Microtechnology. The complete envelope amplifier presents a 30 dB gain, a 10 MHz small signal bandwidth, being capable of providing 38 V and 3.5 A. Although this is not a power efficient solution, it allows evaluating the linearity behavior of the designed PA under drain modulation condition.

Being the envelope amplifier bandwidth not enough for manipulating the amplitude component of a 20 MHz WiMAX signal, a proof-of-concept software-manipulated narrow bandwidth test signal was created, shown in Fig. 7.

As expected, the amplitude component of the generated test signal has the same Rayleigh distribution of the original OFDMA signal.

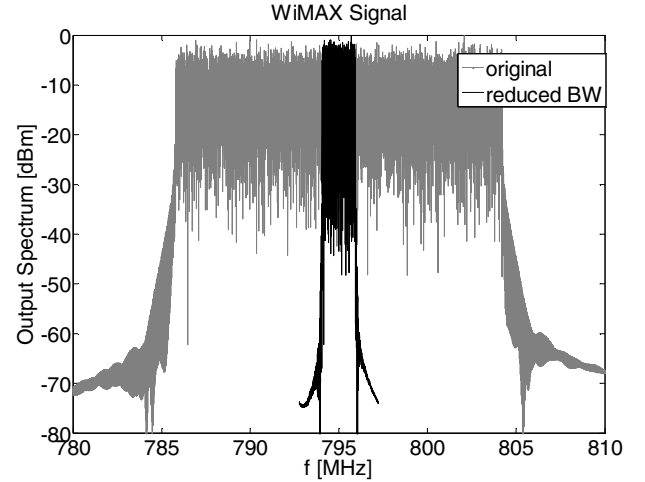

Fig. 7. 20 MHz (original) and 2 MHz (software reduced) bandwidth WiMAX signal spectra.

Based on the above described conditions, the class E RF PA was excited by a phase modulated carrier and the drain voltage controlled according to the desired OFDMA format amplitude component of the Mobile WiMAX signal. The average RF PA efficiency and the linearity results (without pre-distortion) are summarized in next table.

Table I: RF PA results under drain modulation.

$\langle P_{out} \rangle$	$\langle PAE \rangle$	EVM
6.33 W	77.75%	3.24%

In Fig. 8, the measured output spectrum is finally shown. The spectral mask has been scaled with respect to the bandwidth. As it can be appreciated, although the linearity is quite good, digital predistortion is required to meet the spectral mask.

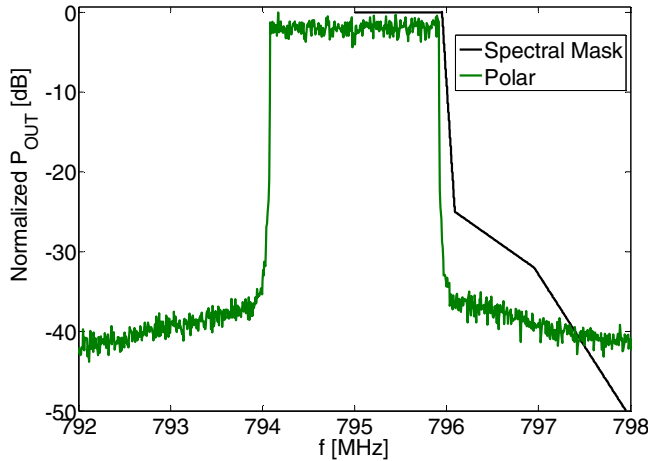

Fig. 8. Normalized output spectrum.

IV. CONCLUSIONS

The design of a Tx line class E power amplifier, aimed to be used as final stage for an IEEE 802.16e Mobile WiMAX polar transmitter has been presented. The high average PAE value is a result of taking into account the modulated signal statistics

in the design process. Digital pre-distorting functions would be required to fit the stringent spectral masks of the standard.

ACKNOWLEDGEMENT

The first and last authors would like to acknowledge the financial support provided by Ministerio de Ciencia e Innovación through Projects TEC2008-06684-C03-01 and CSD2008-00068. The second and third authors would like to thank Portuguese Science Foundation, F.C.T., and Instituto de Telecomunicações for the financial support provided under Projects PTDC/EEA-TEL/65988/2006 Digital_PAs and SWIPA Ref. Nr.: P423, respectively.

The authors would also like to thank Ryan Baker, Cree Inc., for his kind attention and the device model support.

REFERENCES

- [1] I. Kim, Y. Y. Woo, J. Kim, J. Moon, J. Kim, and B. Kim, "High-efficiency Hybrid EER Transmitter using Optimized Power Amplifier," *IEEE Trans. on Microwave Theory and Tech.*, vol. 56, no. 11, pp. 2582-2593, Nov. 2008.
- [2] L. R. Kahn, "Single-Sideband Transmission by Envelope Elimination and Restoration," *Proc. IRE*, vol. 40, no. 7, pp. 803-806, Jul. 1952.
- [3] J. C. Pedro, J. A. Garcia and P. M. Cabral, "Nonlinear Distortion Analysis of Polar Transmitters", *IEEE Trans. on Microwave Theory and Tech.*, vol. 55, no. 12, Part 2, pp. 2757-2765, Dec. 2007.
- [4] F. Wang, D. Kimball, J. Popp, A. Yang, D. Tie, P. Asbeck and L. Lawson, "An Improved Power-Added Efficiency 19-dBm Hybrid Envelope Elimination and Restoration Power Amplifier for 802.11g WLAN Applications", *IEEE Trans. on Microwave Theory and Tech.*, vol. 54, no. 12, pp. 4086-4099, Dec. 2006.
- [5] N. A. Sokal and A. D. Sokal "Class-E A New Class of High—efficiency Tuned Single-ended Switching Power Amplifiers," *IEEE J. Solid-State Circuits*, vol. SC-10, pp. 168-176, June 1975
- [6] T. B. Mader and Z. Popovic, "The Transmission-Line High-Efficiency Class-E Amplifier," *IEEE Trans. on Microwave Theory and Tech.*, vol. 43, no. 5, pp. 290-292, Sept. 1995