

An Ultra Wideband 5 W Power Amplifier Using SiC MESFETs

Ahmed Sayed, Stefan von der Mark and Georg Boeck

Berlin University of Technology, Microwave Engineering Group, HFT 5-1, Einsteinufer 25, 10587 Berlin, Germany, boeck@tu-berlin.de, Tel. +49 30 31 42 68 95 and Fax. +49 30 31 42 68 93

Abstract— A 5 watt wideband power amplifier using a SiC MESFET has been designed. The frequency range covers 10 MHz to 2.4 GHz with small-signal gain of 8 dB. A broadband choke structure with a new technique was developed to obtain good isolation and low loss over the desired bandwidth. Input and output matching networks and shunt feedback topology were introduced to increase the bandwidth. At $V_{DS} = 30$ V and $I_{DS} = 500$ mA, power performance measurements with PAE of almost 35%, an output power of ≥ 37 dBm and 8 dB power gain over the operating bandwidth were achieved. Two-tone measurements at frequency spacing of 200 kHz were also done and OIP2 and OIP3 of 76 dBm and 49 dBm, respectively, were obtained. Finally, AM/AM and AM/PM distortions were measured and the results are discussed.

I. INTRODUCTION

Features of wide bandgap semiconductors that provide high RF power density, small die size, high breakdown voltage, high frequency operation and less complex amplifier arrangement for the design engineer made such technology a serious challenge to silicon LD MOS for high-power amplification [1-3]. In the last years, many authors [4-6] have utilized SiC MESFETs' performances and their applications for different generations in power amplifier design for use in broadcast digital television, aerospace and military systems. Taking into consideration the advantages of high internal impedance which in turn can simplify impedance matching resulting in efficient power coupling and large bandwidth, we introduce in this paper an ultra wideband power amplifier using a SiC MESFET that covers the frequency range from 10 MHz to 2.4 GHz. Sec. II introduces the amplifier design procedure in 3 steps. The first step is choosing the transistor that satisfies the design requirements. Developing the DC biasing network that meets the desired bandwidth is considered as the second step while the third one deals with input, output matching networks and shunt feedback circuit design resulting in a broadband characteristic. In section III, experimental results are given and discussed. Small-signal gain, stability factor and matching over frequency range from 10 MHz to 2.4 GHz at $V_{DS} = 30$ V and $I_{DS} = 500$ mA are first introduced, then power performance measurements (PAE, Output power and Power gain) at 1 GHz and 2 GHz are shown. Two-tone measurements at frequency spacing of 200 kHz were also done. AM/AM and AM/PM distortion is introduced and discussed at the

end of the section. Finally, the design procedure and the experimental results are concluded in Sec. IV.

II. DESIGN PROCEDURE

A. Transistor Choice:

The first and most important step in power amplifier design is to select a suitable transistor in order to meet the required specifications of an amplifier. In this paper, it is desired to design an amplifier that covers a wide frequency range from 10 MHz to 2.4 GHz with a considerably flat gain of ≥ 8 dB and maximum output power up to 5 watt. The CREE CRF-24010 SiC MESFET has the required specifications of wide frequency range up to 3 GHz, 10 watt at 1 dB compression and 15 dB small signal gain.

B. DC Biasing Network:

In this section the design of a DC biasing circuit that isolates RF from DC in the desired bandwidth is discussed. It simply consists of an inductance (choke) and a capacitance in T-junction (DC feeding and blocking). While designing the broadband choke, it is required to get a large enough inductance at low frequencies and at the same time a sufficiently high self-resonance frequency (SRF). These requirements can be met using ferrite-loaded coils. An efficient and accurate technique was used that depends mainly on building a large number of different air-core and ferrite coils with different sizes (their values depend on the core material, number of turns, wire length and height of core), then testing each one on a board such as in Fig. 1. Reflection and transmission coefficients and the input impedance are measured. A combination of three coils that represent low, mid and high frequency isolation was finally constructed, retested and improved to get a loss lower than 0.4 dB in the overall frequency band. Fig. 2 shows the simulated and the measured reflection and transmission coefficients of the proposed combination over the desired frequency range.

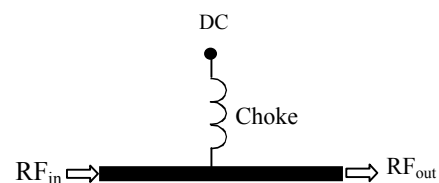

Fig. 1. Schematic of the board for the choke under test.

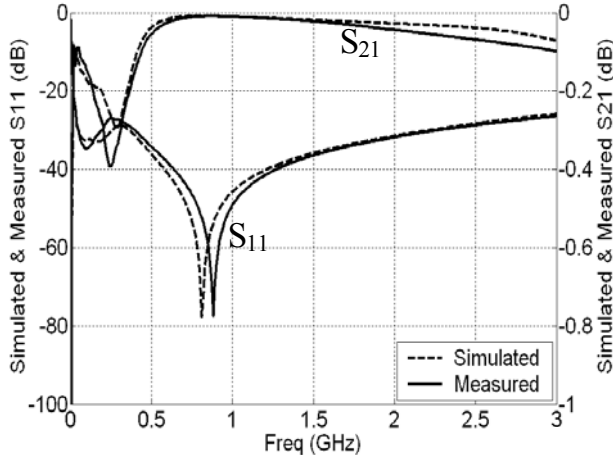

Fig. 2. Simulated and measured S-parameters of broadband choke.

C. Feedback and Matching Networks:

For broadband design, shunt feedback technique is one of the most commonly applied techniques. Referring to Fig. 3, it consists of feedback resistance R_F and capacitance C_F . The value of R_F that satisfies the desired gain is given by:

$$R_F = Z_0 (1 + |S_{21}|) \quad \text{for } |R_F| > Z_0 \quad (1)$$

where $Z_0 = 50 \text{ Ohm}$, $|S_{21}|^2$ is the power gain. The value of the feedback capacitor is chosen to bypass only RF signal and block DC signal between Gate and Drain. Unconditional stability $K > 1$ can be obtained by adding a combination of R_S and C_S in series at the input. A simultaneous conjugate matching at both the input and output ports of an unconditionally stable linear amplifier that delivers maximum power to the load can be simulated in ADS (Advanced Design System) using microstrip transmission lines and shunt stubs. Multi-section matching networks have been used because of their advantage of increasing the bandwidth as much as possible. The complete schematic diagram is shown in Fig. 3. Teflon with dielectric constant of 3.38 and thickness of 0.51 mm was used as substrate material for the matching networks.

III. EXPERIMENTAL RESULTS

Small signal S-parameters, power performances, two-tone measurements and transmission phase distortion of the fabricated power amplifier are presented in this section. The small-signal S-parameters were measured at $V_{DS} = 30 \text{ V}$, $I_{DS} = 500 \text{ mA}$. Figs. 4, 5 respectively show the simulated small signal gain, stability factor (K) and return loss compared to the measured results. Both simulated and measured gain show a low ripple ($\pm 0.5 \text{ dB}$) over the frequency range from 10 MHz to 2.4 GHz. Good agreement can be observed. Power measurements were performed using a RF signal generator in conjunction with a microwave high gain amplifier as power source. Figs. 6, 7 show the measured output power, PAE and power gain as a function of the input power at 1 GHz and 2 GHz, respectively. From these diagrams, it can be seen that an output power of $\geq 37 \text{ dBm}$ (5 watt) at 1 dB compression point, PAE of (33 ~ 34 %) and a power gain of 8 (± 0.5) dB are obtained. Over the frequency range from 10 MHz to 2.4 GHz, the extracted output power, input power and power gain ($P_{out} - P_{in}$) at 1 dB compression point is displayed. It is concluded that an output power of 37 dBm and power gain 8 (± 0.5) dB are achieved. Linearity of the power amplifier was also measured by its two-tone intercept point. Two closely spaced equal amplitude input tones were applied to the circuit at F_0 and $F_0 + \Delta$, respectively where Δ is the frequency spacing between the two tones. The fundamental, second and third order components were detected on a spectrum analyzer as a function of input power. An enhanced multi-tone signal generator (Agilent-ESG) was used to generate two equal amplitude tones at $F_0 = 1 \text{ GHz}$ with frequency spacing $\Delta = 200 \text{ kHz}$ and $P_{in} = 10.4 \text{ dBm}$. The output amplitude spectrum can be demonstrated on the spectrum analyzer (PSA) as shown in Fig. 9. An input power sweep was applied and the output second and third order intercept point ($OIP2$ & $OIP3$) were finally calculated using the equation

$$OIPn = P_{out} + (\text{Harmonic Suppression}) / (n-1) \quad (2)$$

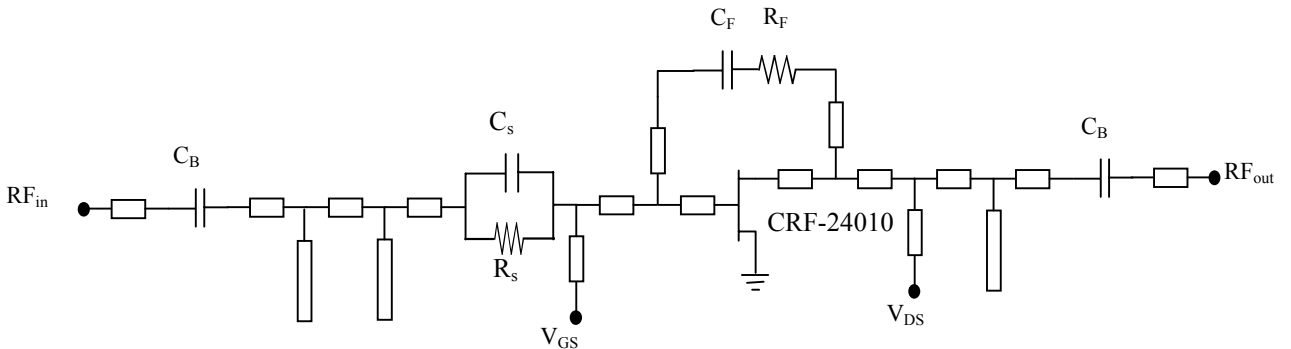

Fig. 3. Schematic diagram of broadband 5 W power amplifier.

where n is the harmonic order. Fig. 10 shows the fundamental, second and third order harmonics as a function of the input power. The diagram shows that an $OIP2$, $OIP3$ of 76 dBm and 49 dBm, respectively have been achieved.

Additional amplifier characterizations can give a more accurate representation of nonlinear distortions in an amplifier. AM/AM distortion is created by the variation in the amplifier gain across different input powers while AM/PM distortion can be defined as a change in the phase between the input and output signals of the amplifier. Figs. 11, 12 show both AM/AM and AM/PM distortions at 1 GHz and 2 GHz, respectively. The amplifier shows excellent results with respect to these quantities, too.

IV. CONCLUSION

A 5 W wideband RF power amplifier stage has been designed using SiC MESFET, covering the frequency range from 10 MHz to 2.4 GHz. A small signal bandwidth with ± 0.5 dB gain flatness was obtained using both feedback and matching circuits. Small signal S-parameters at $V_{DS} = 30$ V and $I_{DS} = 500$ mA were measured. Power performances and amplifier linearity were also measured at the same operating point resulting in 8 dB power gain, 37 dBm output power, 35 % PAE and 49 dBm $OIP3$. The results are discussed and good agreement was achieved between simulations and measurements.

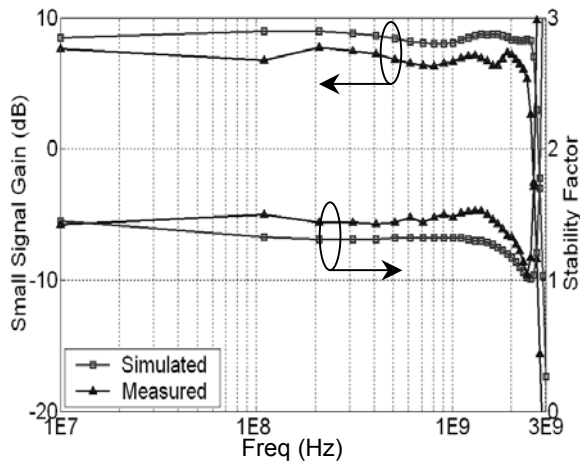

Fig. 4 Simulated and measured gain and stability factor at $V_{DS} = 30$ V and $I_{DS} = 500$ mA.

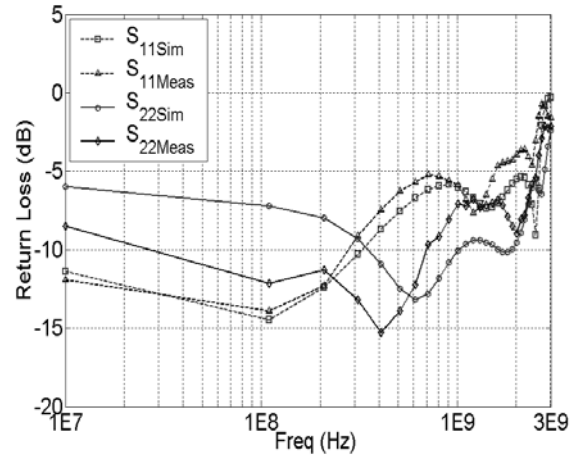

Fig. 5 Simulated and measured return loss at $V_{DS} = 30$ V and $I_{DS} = 500$ mA.

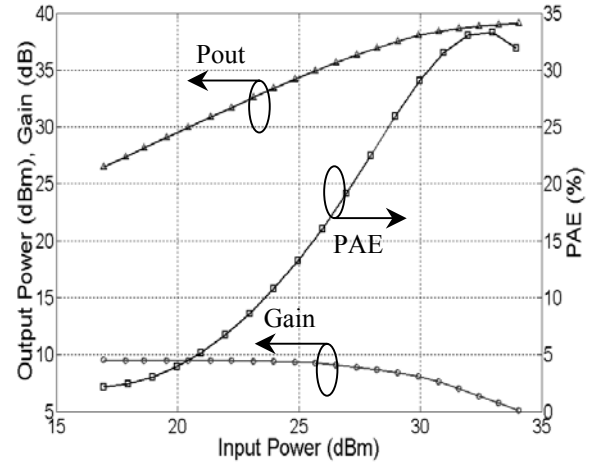

Fig. 6 Power performances measurement at 1 GHz, $V_{DS} = 30$ V and $I_{DS} = 500$ mA.

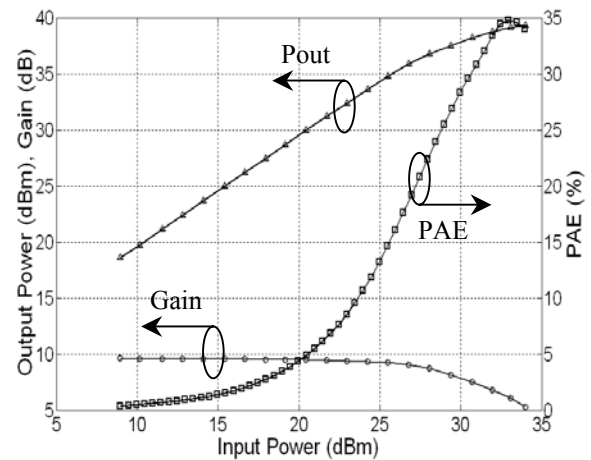

Fig. 7 Power performances measurement at 2 GHz, $V_{DS} = 30$ V and $I_{DS} = 500$ mA.

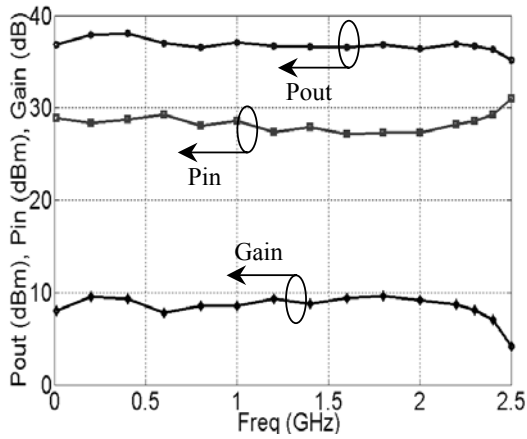

Fig. 8 Power performance measurement versus frequency at $V_{DS} = 30$ V and $I_{DS} = 500$ mA.

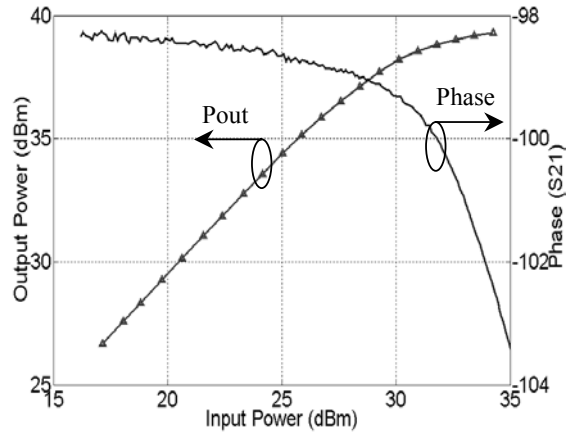

Fig. 11. AM/AM and AM/PM measurements at $F = 1$ GHz, $V_{DS} = 30$ V and $I_{DS} = 500$ mA.

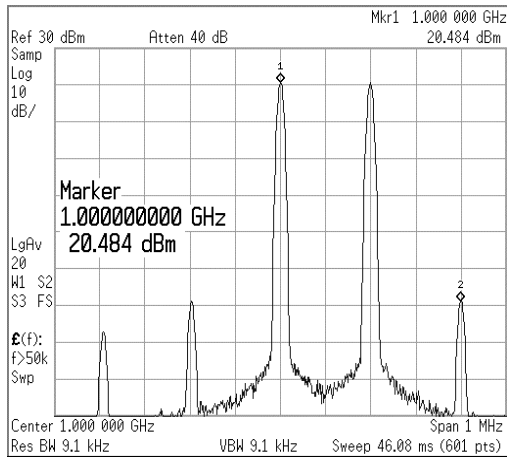

Fig. 9 Two-tone measurement at $P_{in} = 12.4$ dBm, $F_0 = 1$ GHz and $\Delta = 200$ kHz.

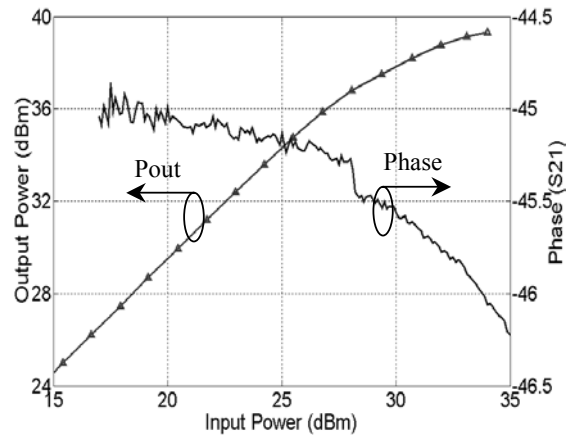

Fig. 12 AM/AM and AM/PM measurements at $F = 1$ GHz, $V_{DS} = 30$ V and $I_{DS} = 500$ mA.

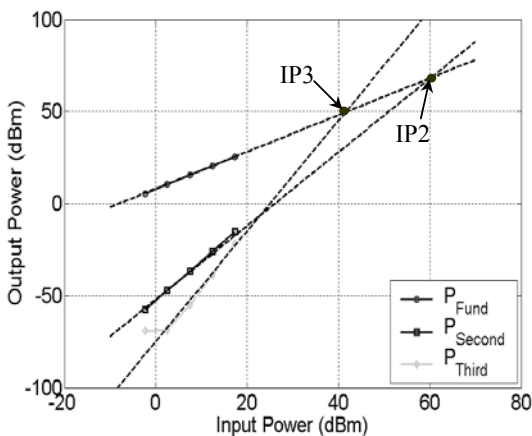

Fig. 10. Linearity measurement at 1 GHz, $\Delta = 200$ kHz, $V_{DS} = 30$ V and $I_{DS} = 500$ mA.

V. REFERENCES

- [1] S. T. Allen *et al*, "Progress in high power SiC microwave MESFETs", IEEE MTT'S Digest, 1999
- [2] J. F. Broch *et al*, "Power amplification with Silicon Carbide MESFET", Microwave and Optical Tech. Letter, Vol. 23, 1999
- [3] F. Temcamani *et al*, "Silicon Carbide MESFETs performances and application in Broadcast Power Amplifiers", IEEE MTT'S Digest, pp. 641-644, 2001
- [4] J. C. M. Hwang, "Wide bandgap semiconductor wide bandwidth wide temperature range Power amplifiers", GaAs IC Symposium, pp. 51-54, 1999
- [5] W. L. Pribble *et al*, "Application of SiC MESFETs and GaN HEMTs in Power Amplifier Design", IEEE MTT'S Digest, pp. 1819-1822, 2002
- [6] H. Xue *et al*, "A high performance ultra-broadband RF choke microwave applications", IEE Colloquium on Evolving Tech. for Small Earth Station Hardware, pp. 1-4, 1995