

Cree® XLamp® LEDs Chemical Compatibility

TABLE OF CONTENTS

Executive Summary.....	1
Introduction	2
An Example of Chemical Incompatibility.....	2
High-Power LEDs and Chemical Compatibility.....	3
Silicone-Encapsulant Chemistry and a Theory of VOC Incompatibility.....	4
Reversibility of VOC Discoloration	8
Material-Selection Considerations	11
Selected Sources of Incompatible Chemistry	11
Selected Chemicals.....	12
Selected Conformal Coatings.....	12
Another Example.....	13
Testing Procedures for Identifying Substances of Concern	14
Cree Materials Test Kits	14
Testing Recommendations	16
Provide Post-Test Information to Cree, Please	17
Conclusion	17
Appendix A.....	18

EXECUTIVE SUMMARY

The presence of incompatible volatile organic compounds (VOCs) in LED illumination systems can accelerate the degradation or impair the performance of LEDs from any manufacturer. This chemical incompatibility is often a localized phenomenon, occurring in sealed portions of the systems where LEDs operate at elevated temperatures with little or no air movement. There are molecules and families of molecules that are known to cause problems. While Cree maintains and publishes lists of known compatible and incompatible chemicals, customer testing is always the best way to develop a strong understanding of chemical incompatibilities. With proper precautions, design, and testing, effects can be minimized or removed. The effects of chemical incompatibility are pronounced in royal blue, blue and white LEDs and never observed in red or green LEDs.

INTRODUCTION

Among the critical factors affecting LED light sources in SSL luminaires and bulbs, maintaining an appropriate operating temperature allows the SSL device to have the longest possible operating life and excellent color point stability.¹ Additionally, minimizing chemical incompatibility between (principally) the LED primary optics and the variety of chemicals used in electronic assembly and SSL luminaire production is similarly critical, because these interactions can impair efficient operation.

The practical result of chemical incompatibility and a too-high LED package temperature is the same: an impairment or degradation of the silicone encapsulant that protects the LED chip from the environment, which leads to less light transmitted from LED package.

In this application note, we will

- Review the sources of chemical incompatibility from the general classes of materials used in solid-state lighting systems
- Show the results and examples of chemical incompatibility
- Review Cree’s recommended best practices to maintain chemical compatibility
- Discuss procedures and protocols for measuring and assessing potential chemical interactions

AN EXAMPLE OF CHEMICAL INCOMPATIBILITY

Figures 1 and 2 shows a fixture based on six XLamp XR-E LEDs. The first photograph shows the fixture when it is first plugged in. After less than 100 hours of operation, there has been a significant yellowing of the illumination source. The third photograph shows the system circuit board, optical covering removed. The LEDs are all discolored, now a burnt orange color – the cause of the illuminated color shift. What has happened? In the space between the circuit board and the covering optical plate is a nearly-sealed micro environment. As the fixture reaches an elevated temperature in normal operation, the most likely culprit is the outgassing of volatile organic compounds has caused this discoloration.

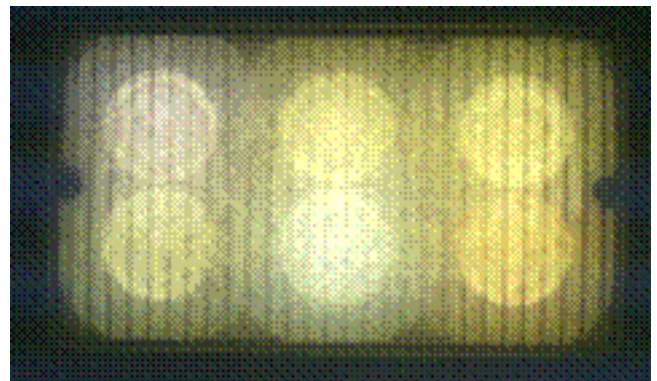
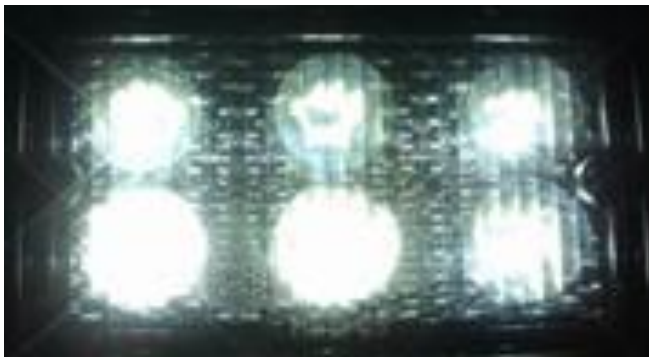

Figure 1: XLamp XR-E-based luminaire, showing signs of chemical incompatibility

1 See Application Note: “Cree® XLamp® Long-Term Lumen Maintenance,” CLD-AP28 -http://www.cree.com/products/pdf/XLampXR-E_lumen_maintenance.pdf.

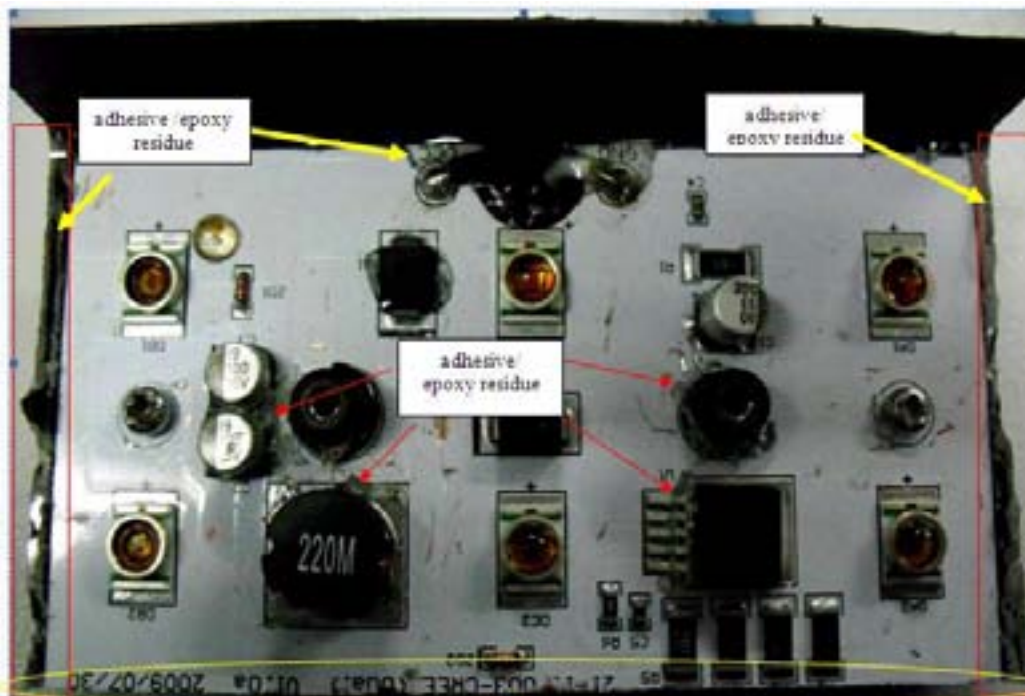

Figure 2: The circuit board of the luminaire in Figure 1

A brief inspection of the circuit board shows there are almost as many potential chemical contaminants as there are electrical components. There is solder and flux proximate to the components, epoxy adhesive at the edges of the board, residue around several of the components and there appears to be a conformal coating over the electrical components. Until it is ruled out, even the ink used to mark the circuit board is considered a potential contaminant. One or more of these materials has had an adverse chemical interaction with the LEDs. This chemical incompatibility is particularly difficult because it is not just an isolated defect but represents the contamination of an entire production run. Understanding and preventing these kinds of incompatibilities is extremely important.

HIGH-POWER LEDs AND CHEMICAL COMPATIBILITY

The example above, while involving Cree XLamp XR-E LEDs can occur with high-power LEDs from any manufacturer who builds with a silicone-based dome, lens or encapsulants. The silicone-based encapsulants used by the industry are both highly transmissive and also gas permeable, therefore susceptible to these phenomena.²

	High-Brightness LEDs	High-Power LED
Encapsulant system	Acrylic or epoxy	Silicone (XP, MX, ML,...) Glass/silicone (XR, MC)
Thermal management	No thermal management	Isolated thermal pad
Current capacity	10 – 100 mA	100 – 4000 mA

² Philips Lumileds also documents these handling concerns in their Application Brief, AB36, LUXEON c Series Assembly and Handling Information, available at www.philipslumileds.com/uploads/16/AB36-pdf

Through-hole (eg. P2 and P4) product designs, often called High Brightness LEDs, such as the Cree C4SMJ and C4SMK use different construction techniques, including the use of acrylic primary optics/encapsulants and are less susceptible to certain of these phenomena.

SILICONE-ENCAPSULANT CHEMISTRY AND A THEORY OF VOC INCOMPATIBILITY

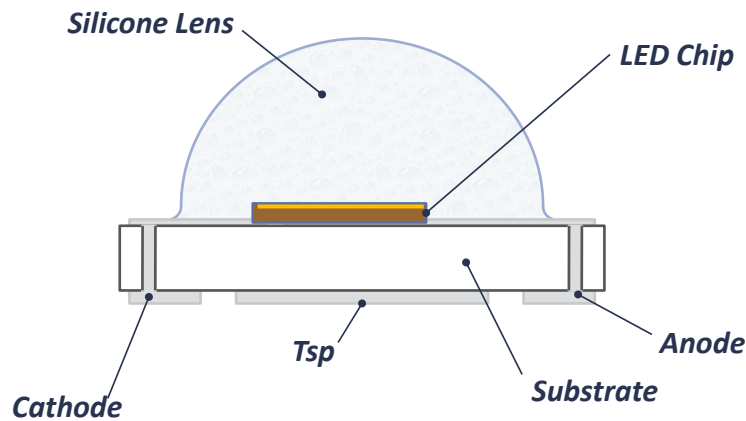
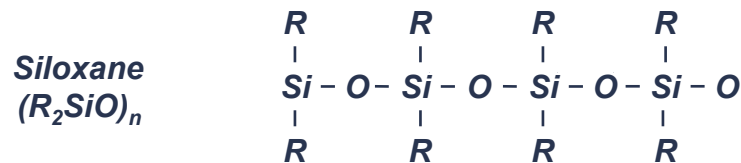

Figure 3: XLamp XP-E cross section showing silicone lens

The encapsulants used on high-power LEDs, such as Cree XLamp LEDs, are made of a variety of silicone-based materials. Silicones have excellent light transmittance, are stable over wide temperature ranges, are resistant to yellowing due to UV exposure and can be dispensed or molded easily – all properties that can contribute to achieving long lumen maintenance with LEDs.

The basic structure is a molecule in the form of a chain of silicon-oxygen (SiO)_n, or Si-O-Si-O-Si-O.... For the transparent optical dome application, there are a few major families of polyorganosiloxanes (siloxanes) where a hydrocarbon is covalently bonded to the silicon. The covalent bonds make for a stable operating environment, with no break down unless temperatures exceed 200° C, well above the rated operating temperature of LEDs. Encapsulants employing both methyl and phenyl pendant groups are common in this application.



(R = functional hydrocarbon group)

Figure 4: Siloxane compounds

As an example, one of the common silicones used as an LED encapsulant is methyl siloxane. This compound is formed by bonding a methyl group (CH₃) to the silicone-oxygen chain to create [SiO(CH₃)₂]_n, shown in figure 5, below.

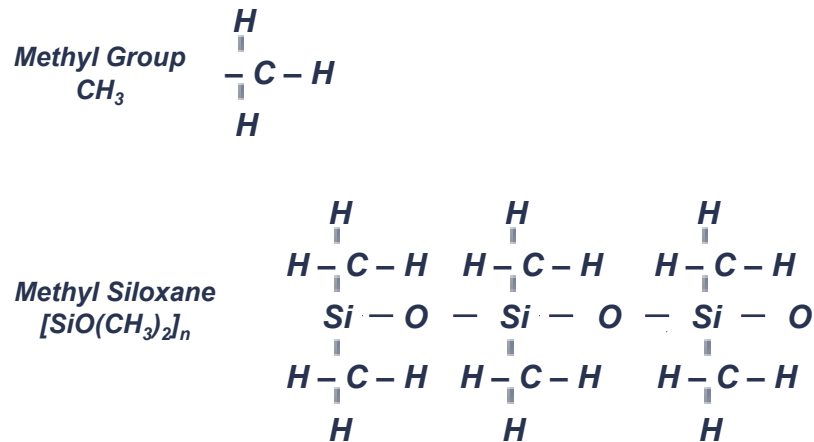

Figure 5: Methyl siloxane encapsulants

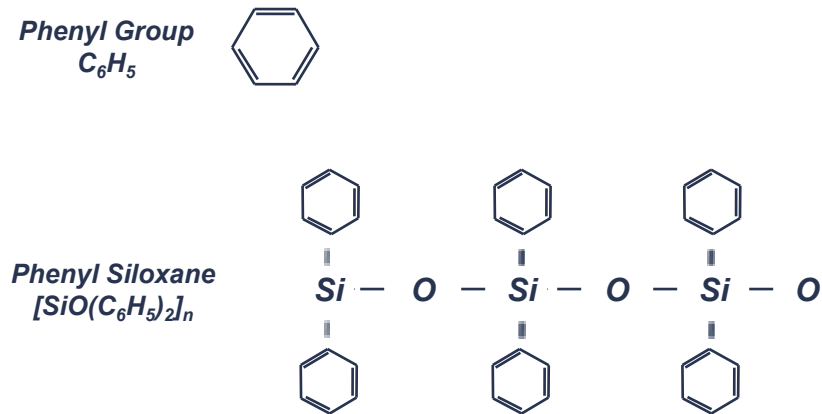

Figure 6: Phenyl siloxane encapsulants

All of these silicones are poured into a mold as liquid and cured into a permanent dome as a part of the LED manufacturing process. During the curing process, the siloxanes do not assume any regular or organized structure. Rather, they cure into interwoven random strands of varying length and shape. This gives rise to the slightly gelatinous and resilient feel associated with cured silicones. It also means these are porous and gas-permeable materials.

Glues, conformal coatings, o-rings, gaskets, and potting compounds are materials frequently used in the construction of luminaires, bulbs, or other solid-state lighting products. During the operation of the lighting fixtures, heating takes place, and some of these materials are known to emit volatile organic compounds (VOCs). In any type of sealed environment (such as beneath secondary optics or fixture covers), the VOCs will surround the LED and diffuse into the porous

silicone encapsulant. There in the silicone, the VOCs will occupy a free space within the interwoven siloxanes chains. With subsequent exposure to heat and high-energy photons emitted from the LED, the volatile compounds can discolor and block the light emitted from the LED. This discoloration usually occurs just above the top surface of the LED chip since that is where the highest temperature and flux density is located. An accompanying shift in chromaticity is also frequently observed. Depending on the nature of the VOC (e.g. the size of the molecule or its sensitivity to heat), this discoloration can occur in a matter of hours or it may take several weeks. This discoloration happens to blue LEDs or white LEDs that are built using blue chips with phosphors. It does not happen to amber, red or green LEDs since these colors have longer, lower-energy wavelengths.

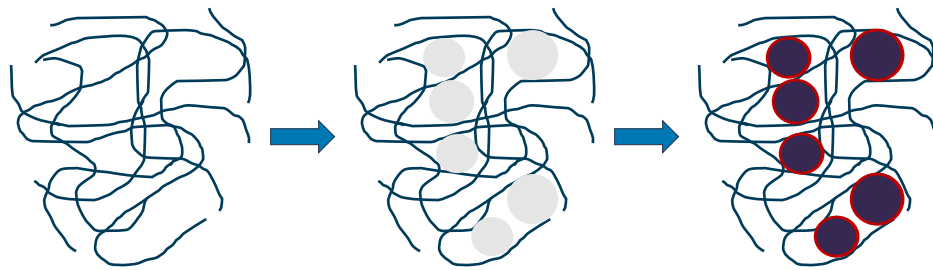

Figure 7: Left to right - Silicone chains; VOCs occupying free spaces in the silicone; VOC discoloration as a result of exposure to heat and photonic energy



Figure 8: The image on the left is the normal appearance of a chip in an XLamp XP-E LED. The chip in the image on the right has discolored due to exposure to VOCs.

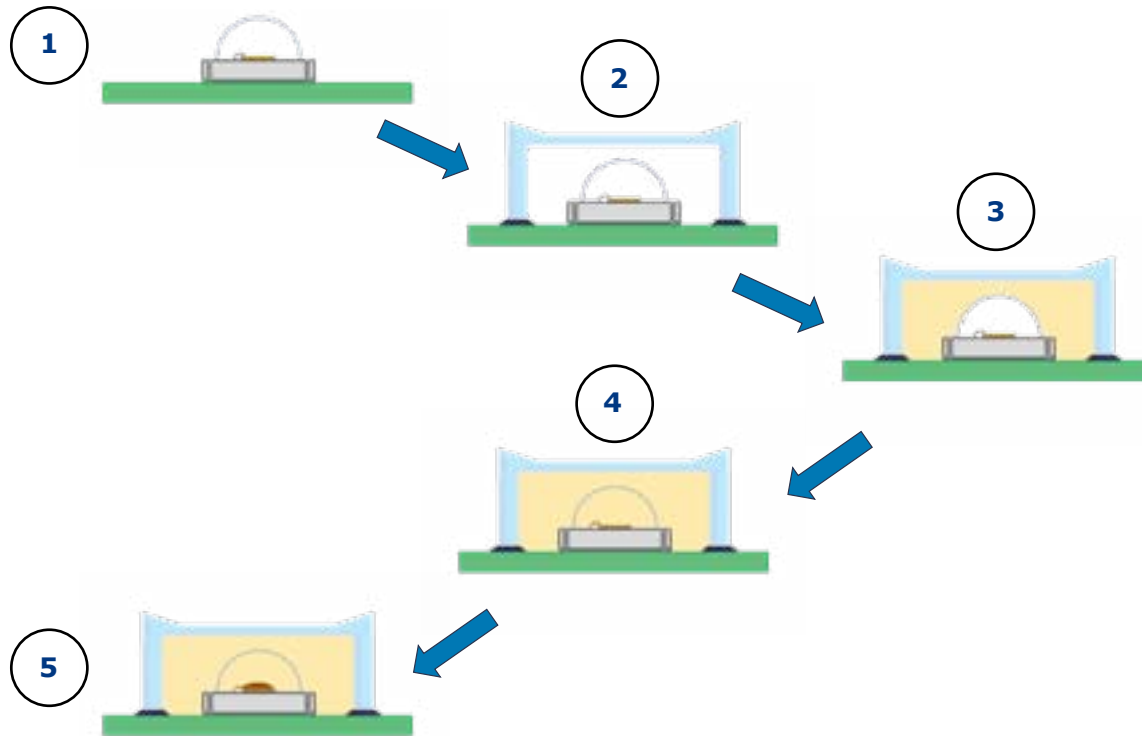

Figure 9: An example of the progression of VOC discoloration of an LED:

1. LED is mounted to a PC board.
2. A secondary optic is attached to the board with glue.
3. VOCs emitted from glue are trapped beneath optic.
4. The volatiles diffuse through silicone lens.
5. The VOCs in the encapsulant above chip surface discolor.

Factors that affect discoloration of the VOCs include heat, photonic energy and wavelength. Discoloration occurs around the top surface of the LED chip because this is where the greatest heat and flux density comes into contact with the silicone lens. Examples of chemical incompatibility in the XLamp XP package are shown in Figure 10.

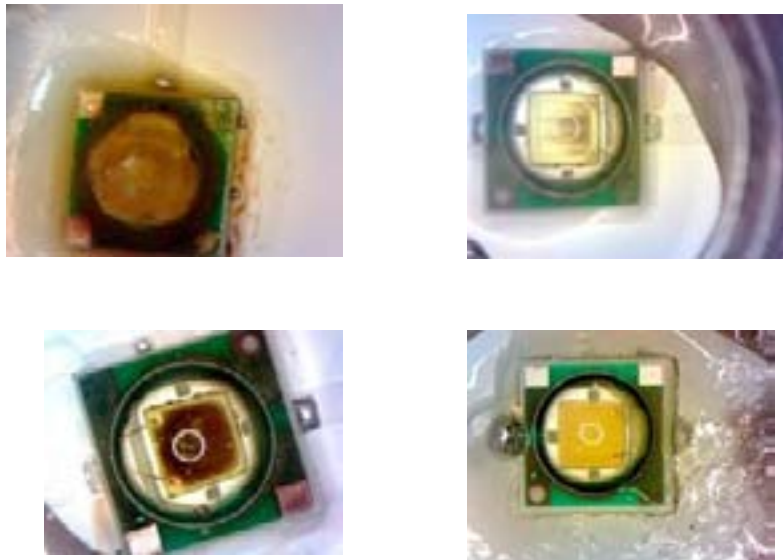

Figure 10: A variety of XLamp LEDs showing chemical incompatibility

REVERSIBILITY OF VOC DISCOLORATION

As noted, the discoloration of the encapsulant above the LED chip is due to a darkening of the VOCs that have diffused into the silicone from outside of the LED component. In most cases these volatiles, occupying a free space within the encapsulant, do not cause damage to the silicone itself.

In such situations, if the optic or cover above an LED that has discolored is removed, and the fixture continues to be operated, then the VOCs can outgas from the encapsulant and the discoloration in the silicone will clear. As with the initial discoloration of the material, depending on the nature of the volatile compound that has diffused into the silicone, this clearing can occur in a matter of hours or could take several weeks. The photographs shown in Figure 11 are examples of this type of outgassing.

There are, however, some VOCs that can damage the encapsulant, causing it to swell and crack, rendering the LED unacceptable for future use.

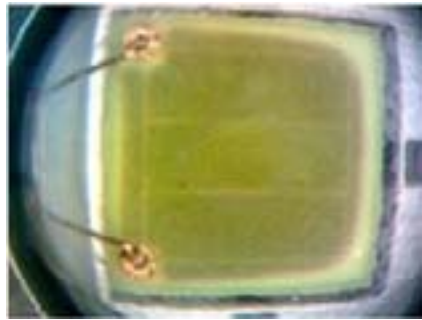

1. As received

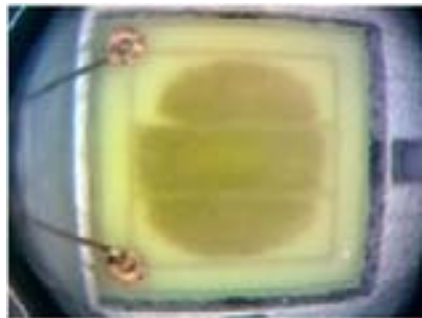

2. After 24 hours of operation

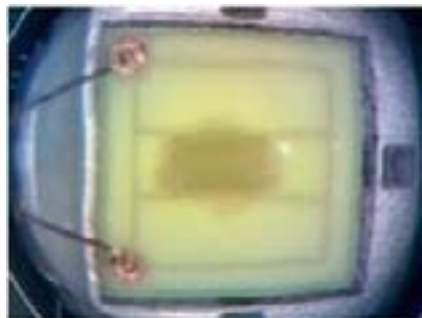

3. After 48 hours of operation



4. After 72 hours of operation

Figure 11: The progression of VOC outgassing from an LEDs silicone encapsulant. This XLamp XP-E LED was exposed to VOCs beneath a secondary optic in a fixture. The volatiles caused the encapsulant to discolor and block the light being emitted from the LED. The optic was removed from above the LED, and it was operated for three days. Each day more of the VOC contaminant outgassed from the LED until it was clear.

Cree’s application engineering team conducted a chemical compatibility experiment to demonstrate the effect of reversibility. A summary graph is displayed below. Over an interval of 450 hours, three sets of 10 LEDs each, a total of 30, LEDs were subjected to three different protocols. The first group of ten LEDs operated in an open-air environment and showed no degradation from the initial 100-lumen reading. A second group of LEDs was set to operate in a sealed environment with a known chemically incompatible material. It suffered a 90% loss of output after 400 hours. A third group of LEDs was placed in a sealed environment with the same incompatible compound. These too suffered a 90% loss of luminous output, but at 325 hours of operation, the enclosure was vented. Over the next 25 hours, the LEDs recovered virtually all of their luminous output.

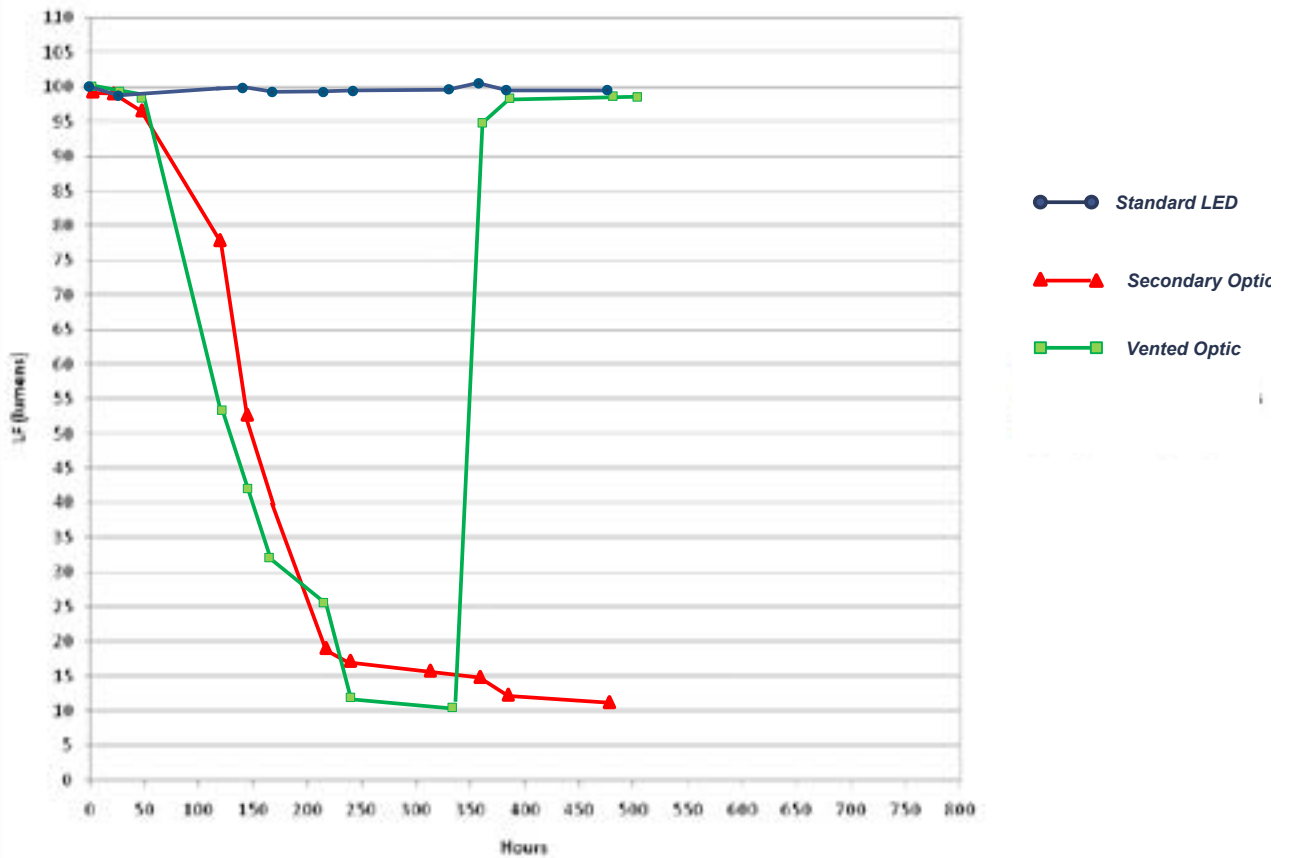

Figure 12: Results of chemical compatibility test to investigate reversibility of VOC discoloration

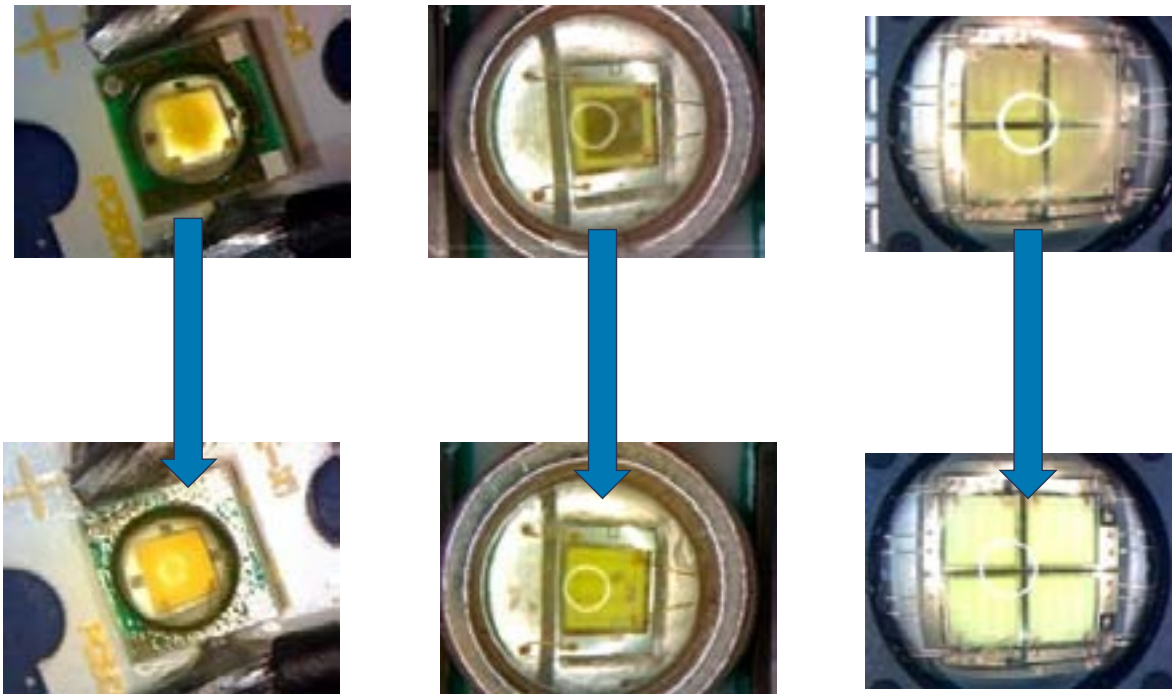

Figure 13: Examples showing the reversibility of VOC discoloration

MATERIAL-SELECTION CONSIDERATIONS

Testing of materials used in luminaires prior to production can help prevent unexpected problems once the product is in production and operation in the field. Special consideration needs to be given to gasket materials, solder flux and residual chemistry, such as machine oil, on metal surfaces. Anything that will come into contact with the LED lens should be carefully considered. Even FR-4 boards can outgas at elevated operating temperatures.

Cree has developed a straight-forward testing sequence that can be used to confirm the compatibility of a chemical or material of interest with our XLamp LEDs. Using this process, Cree has identified a list of known compatible and incompatible chemicals and compounds. While it is impossible for Cree to test every material for compatibility, this information can provide a starting framework for selecting and working with fixture and product materials.

Selected Sources of Incompatible Chemistry

In testing, Cree has found the following chemicals to be harmful to XLamp LEDs. Cree recommends not using these chemicals anywhere in an LED system containing XLamp LEDs. The fumes from even small amounts of these chemicals may discolor or damage the LEDs.

Chemicals that can outgas aromatic hydrocarbons (e.g., toluene, benzene, xylene)
Methyl acetate or ethyl acetate (i.e., nail polish remover)
Cyanoacrylates (i.e., "Superglue")
Glycol ethers (including Radio Shack® Precision Electronics Cleaner - dipropylene glycol monomethyl ether)
Formaldehyde or butadiene (including Ashland PLIOBOND® adhesive)
Dymax 984-LVUF conformal coating
Loctite Sumo Glue
Gorilla Glue
Bleach
Bleach-containing cleaners, sprays
Loctite 384 adhesive
Loctite 7387 activator
Loctite 242 threadlocker

Selected Chemicals

In testing, Cree has found the following chemicals to be safe to use with XLamp LEDs.

Selected chemicals safe for use with XLamp LEDs
Water
Isopropyl alcohol (IPA)
Arctic Silver & Arctic Alumina brand thermal grease
3M Scotch-Weld epoxy adhesive DP-190 (polymeric diamante, kaolin)

Selected Conformal Coatings

In testing, Cree has found the following conformal coatings to be safe to use with XLamp LEDs. Conformal coating should not be applied directly to or over the LED lens, as this may affect LED optical performance and reliability.

Selected conformal coatings
Dow Corning 3-1953
Dow Corning 1-4105
Dow Corning 1-2577
Dymax 9-20557
Humiseal 1H20AR1/S
Humiseal UV40
Humiseal 1B51NS
Humiseal 1B73
Humiseal 1C49LV
Shat-R-Shield
Specialty Coating Systems – Parylene
TechSpray Turbo-Coat Acrylic Conformal Coating (2108-P)

The Cree application engineering team is constantly expanding experience with compatible and incompatible chemistries. As part of your manufacturability evaluation, in addition to any testing you might do, you should be in contact with your local Cree Field Application Engineer for updates on Cree’s latest experiences with compatible and incompatible materials.³

Another Example

The following sequence of pictures documents another case of chemical incompatibility. In this case, Cree investigated the source of LED discoloration even though the LEDs were not in a sealed environment. The first sequence of pictures identifies the problem: a discolored LED on the luminaire and the initial disassembly of the luminaire.



Figure 14: Sometimes discovering the source of chemical incompatibility can be a like solving a mystery.

³ Cree advises against the use of any chemicals or materials that have been confirmed to have an adverse affect on device performance or reliability. The results obtained and listed above are explicit to the test method, volume of material applied and environmental conditions of which it was performed. To verify compatibility, Cree recommends that all chemicals/materials be tested in the specific application/environment for which they are intended to be used. These lists are provided for informational purposes only and do not guarantee or imply a warranty against damage, performance or reliability associated with the use of chemicals or materials supplied by the customer or third party.

The problem was revealed as the disassembled unit sat overnight. The next day evidence of outgassing from the small gaskets was evident, shown below. The gasket material, coming into contact with the LED lens, offered a source of VOCs, and the contact between the lens and the gasket offered a migration path that led to LED discoloration.

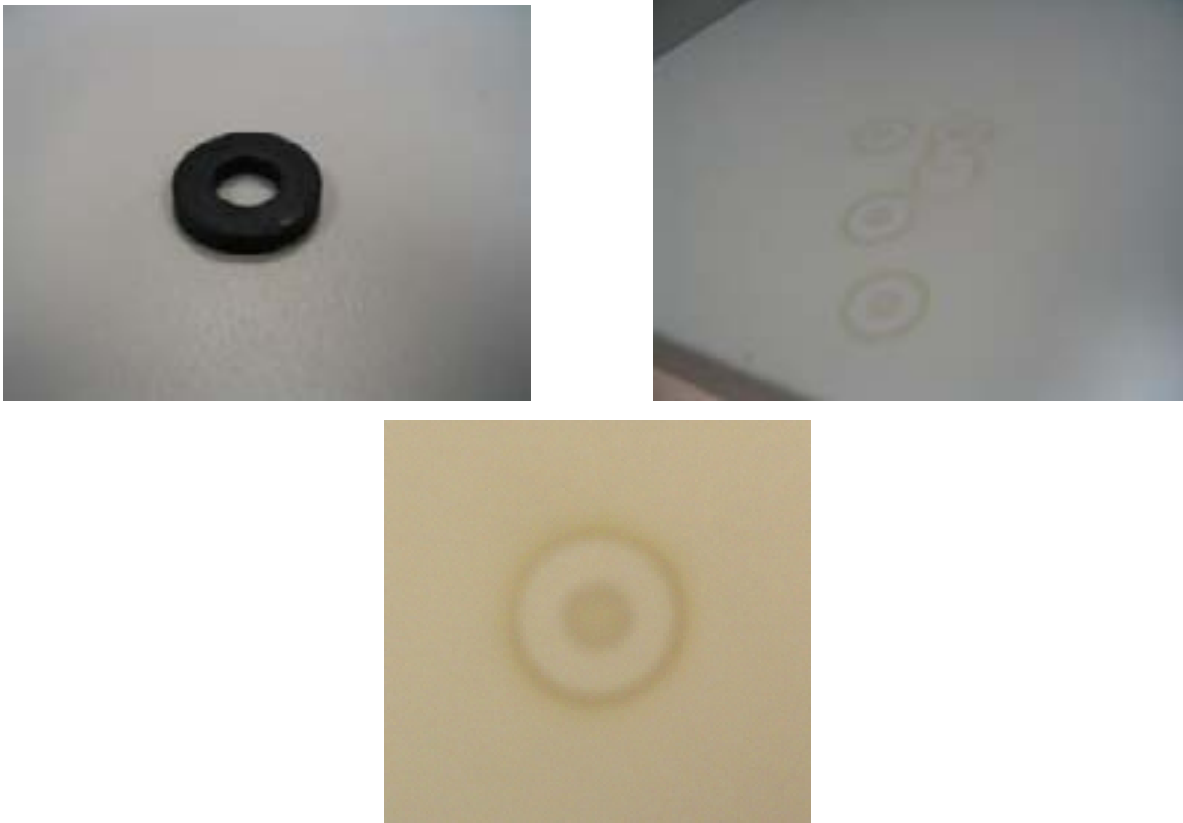

Figure 15: The culprit

TESTING PROCEDURES FOR IDENTIFYING SUBSTANCES OF CONCERN

The best way to develop confidence of chemical compatibility for materials used in luminaire, lamp or fixture construction is to test unknown substances. While Cree can't test every material for chemical compatibility, any customer can be equipped with a kit to verify whether specific materials could cause issues for the LEDs. Your Cree Field Application Engineer can obtain a Materials Test Kit for you.

Cree Materials Test Kits

Cree can provide a materials evaluation kit consisting of one or more four-LED circuit boards, glass caps, adhesive packed in a plastic case. Circuit boards with XLamp XP-C or XP-E LEDs are standard, but MX-3 or MX-6 LEDs on circuit boards can be provided to customers who are evaluating materials used in fixtures containing XLamp ML, MX or CXA LEDs.



Figure 16: Cree Material Test Kit

The kits are used to create small, sealed enclosures where a single material or chemical can be evaluated for its effect on a single LED. A material or chemical of interest is placed near or on the LED. An adhesive seal (the diameter of the glass cover) is set around the base of the LED, and the LED and material are sealed in the cover. Then the circuit board is turned on and evaluations of discoloration can be made over time.

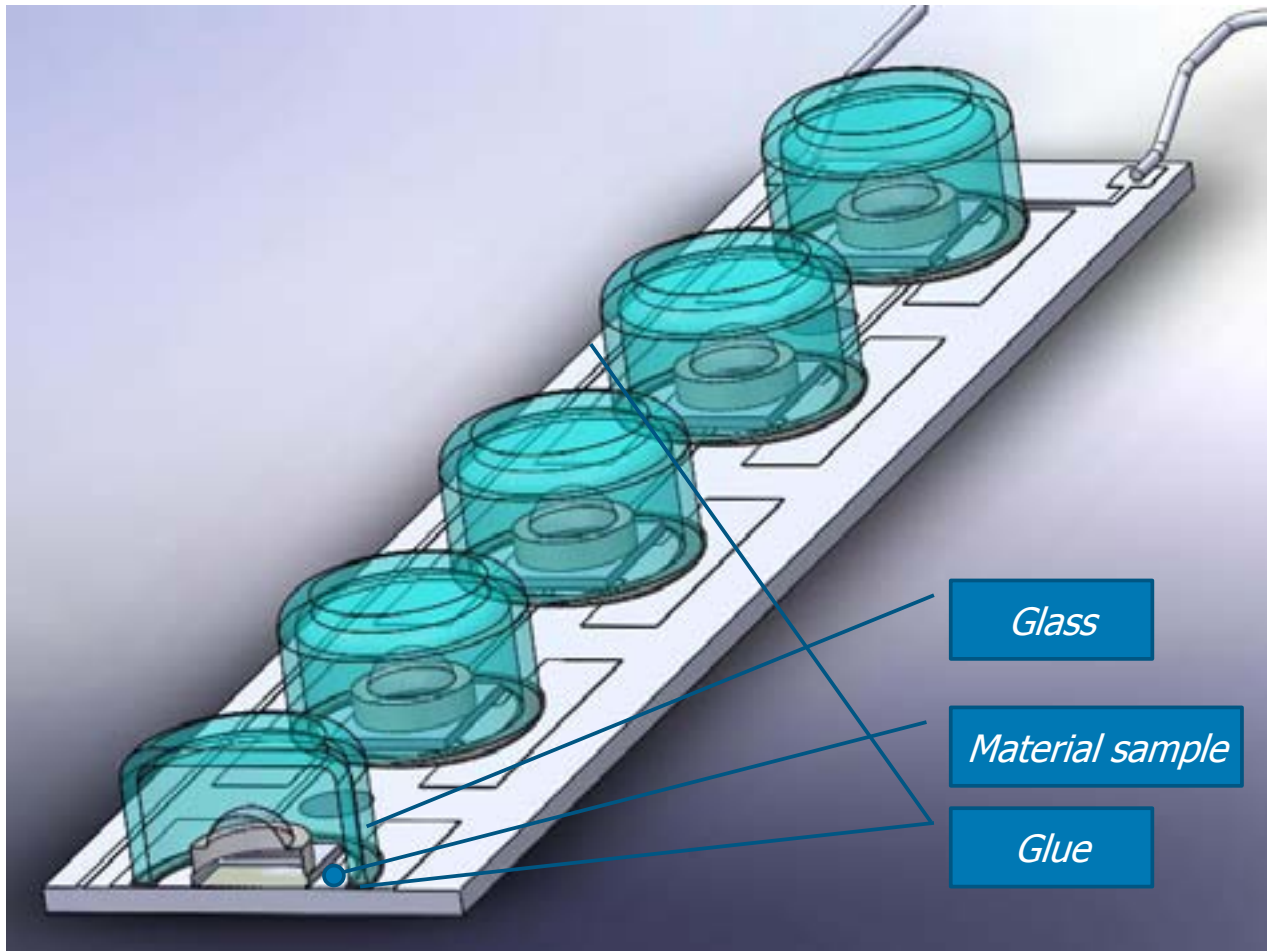

Figure 17: Sealed-enclosure mini-test environments

Testing Recommendations

- For coatings, place sample ON the LED lens and at the lens/LED boundary
- For materials present, but not contacting the LED (like gaskets), place sample on board next to LED
- Run sample at anticipated current or higher, with less heat sinking than in the application
- Look to achieve a (slightly) higher temperature than the fixture will have in normal operation. Cree does recommend always running tests at less than the maximum specified T_j .
- Run tests for at least 6 weeks.
 - a. After 1 week, initial results should be visible
 - b. After 6 weeks, tests should be conclusive
 - c. If LED encapsulant discolors, try removing the glass covering and continuing the test to see if the discoloration diminishes.

Provide Post-Test Information to Cree, Please

For the benefit of all of Cree's customers Cree strives to maintain the most accurate information and highest standards concerning all aspects of design and manufacture of solid state lighting systems. We are eager to receive the results of the materials you test and this information will be added to our materials database and be reflected in future versions of Appendix A, the list of compounds, materials and their viability for SSL manufacturing. Your Cree Field Applications Engineer will be glad to receive this information.

Please include the following information (about the original fixture):

- Type of LED tested
- Material trade name (e.g. "Superglue")
- Active chemicals as listed on the packaging or datasheet
- Type of board and soldering process
- I_F , T_S and T_A of board and system
- Duration of test
- Pictures of affected LEDs

Optional information but very helpful:

- Differences in luminous flux or peak intensity
- Differences in color (CCx, CCy or u' , v')
- Amount of lumen recovery after cap removed

CONCLUSION

VOCs emitted from materials used in the construction of SSL fixtures can penetrate silicone encapsulants of LEDs and discolor when exposed to heat and photonic energy. The result can be a significant loss of light output from the fixture. Knowledge of the properties of the materials selected to be used in the construction of fixtures can help prevent these issues. Cree maintains a detailed list of materials that have been found to be incompatible with LEDs as well as materials that have been tested and found not to adversely affect the fixture characteristics.

APPENDIX A

This is a table of compounds and materials that are often found in electronic and electrical devices along with Cree's assessment of the viability of the compound in SSL luminaire construction. This list is current as of August 2011 and is often expanded or updated. Be sure to consult your local Cree Field Application Engineer for the most current information concerning chemical compatibility.

Material	Type	OK In App	Outgas Tested	Issues Suspected	Issues Found	Tested LED(s)	Conditions
3M DP 270	Adhesive		x		x	XRE	6wks Std. Plas. Cap.
3M Scotch-Weld DP 190	Adhesive	x	x			XRE	6wks Std. Plas. Cap.
3M Scotch-Weld DP 460	Adhesive	x	x			XRE	6wks Std. Plas. Cap.
3M Scotch-Weld epoxy adhesive DP-190 (polymeric diamante, kaolin)	Sealants and adhesives	x	x			XRE	
3M Scotch-Weld epoxy adhesive DP-190 (polymeric diamante, kaolin)	Adhesive	x	x			XP,XR,MX	6wk std glass cap
ACC AS1820 silicone sealant	Coating/Potting		x		x	XRE	6wks Std. Plas. Cap.
Acetic acid /Acid	Acid			x			
Acetone	Manufacturing materials	x			x		
Acrylic adhesives (Two component)	Sealants and adhesives	x			x		
Acrylic latex caulk	Cleaning agents	x	x			XRE	
Acrylic rubber	Rubber/ Plastic seals			x			
Acrylonitrile-Butadiene-Styrene ABS	Structural plastic	x					
Ammonia /alkali	Alkaline			x			
Arctic Silver & Arctic Alumina brand thermal grease	Thermal compound	x	x			XRE	
Arctic Silver & Arctic Alumina brand thermal grease	Thermal compound	x	x			XP,XR,MX	6wk std glass cap
Baiyun-SMG533	Coating/Potting	x	x			XPE, XRE	Dry 72hrs
Benzene /solvent	Solvent			x			
Bostik ISR 70-03	Adhesive	x	x			XPE	6wk std glass cap
Butadiene rubber	Rubber/ Plastic seals			x			
Butyl rubber	Rubber/ Plastic seals			x			
Castor oil /oil	Oil/ lubricant			x			
Chlorinated polyethylene	Rubber/ Plastic seals			x			
Chlorobutyl	Rubber/ Plastic seals			x			
Chlorosulphonated	Rubber/ Plastic seals			x			
Circa lok 6150	Epoxy adhesive		x		x	XP,XR,MX	6wk std glass cap
Clorox bleach	Solvent		x		x	XRE	
Clorox bleach	Cleaning agents		x		x	XP,XR,MX	6wk std glass cap
Clorox Clean-Up cleaner spray	Solvent		x		x	XRE	
Clorox Clean-Up cleaner spray	Cleaning agents		x		x	XP,XR,MX	6wk std glass cap
Corrosion resistant anti-seize	anti-seize material		x		x	XR,XP,MX	6wk std glass cap
Cutting fluids (oil & water based)	Manufacturing materials	x			x		
Cyanoacrylate (Superglue)	Sealants and adhesives		x		x		

Material	Type	OK In App	Outgas Tested	Issues Suspected	Issues Found	Tested LED(s)	Conditions
Cyanoacrylates (i.e., "Super-glue")	Adhesive		x		x	XRE	
DCA SCC3	Coating/Potting	x	x			XRE	Dry 72hrs
Devcon X0152 Epoxy Resin Plus	Adhesive						6wk std glass cap
Dichloromethane /solvent	Solvent			x			
Dow Corning 7097+Dow Corning TC5625	Coating/Potting	x	x			XRE	Wet/Dry 72 hrs
Dow Corning 1-2577	Coating/Potting	x	x			XP,XR,MX	6wk std glass cap
Dow Corning 1-4105	Conformal Coating	x	x			XRE	
Dow Corning 1-4105	Coating/Potting	x	x			XP,XR,MX	6wk std glass cap
Dow Corning 3-1944	Silicon adhesive (RTV)	x	x			XP,XR,MX	6wk std glass cap
Dow Corning 3-1944	RTV	x	x			XR,XP,MX	6wk std glass cap
Dow Corning 3-1953	Conformal Coating	x	x			XRE	
Dow Corning 3-1953	Coating/Potting	x	x			XP,XR,MX	6wk std glass cap
Dow Corning 7091	Coating/Potting	x	x			XPE, XRE	Dry 72hrs
Dow Corning 7096	Coating/Potting	x	x			XRE	Wet/Dry 72 hrs
Dow Corning 734 silicone sealant	Coating/Potting	x	x			XRE	6wks Std. Plas. Cap.
Dow Corning 9185	Silicon adhesive (RTV)	x	x			XP,XR,MX	6wk std glass cap
Dow Corning 9186	Silicon adhesive (RTV)	x	x			XP,XR,MX	6wk std glass cap
Dow Corning antiseize molykote	Anti-seize material		x		x	XR,XP,MX	6wk std glass cap
Dow Corning EA-2800	RTV	x	x			XR,XP,MX	6wk std glass cap
Dow Corning OE-6450	Optical gel	x	x		x		6wk std glass cap
Dow Corning SE-4486	RTV	x	x			XP,XR,MX	6wk std glass cap
Dow Corning TC-4015	RTV	x	x			XR,XP,MX	6wk std glass cap
Dow Corning TC-5121	Thermally conductive compound	x	x			XP,XR,MX	6wk std glass cap
Dow Corning TC-5625	Coating/Potting	x	x			XRE	Wet/Dry 72 hrs
Dow Corning 3-1744	Coating/Potting	x	x			XPE	Dry 72hrs
Down Corning SE-9184	RTV	x	x			XP,XR,MX	6wk std glass cap
Down Corning TC-4025	Thermally conductive compound	x	x			XP,XR,MX	6wk std glass cap
DP-105	Adhesive	x	x				6wk std glass cap
Dymax 9-20557	Conformal coating	x	x			XRE	
Dymax 9-20557	Coating/Potting	x	x			XP,XR,MX	6wk std glass cap
Dymax 984-LVUF conformal coating	Coating		x		x	XRE	
E-00ns (Loc Tite)	Adhesive		x		x		6wk std glass cap
E-6000	Adhesive		x		x		6wk std glass cap
Dow Corning EA-4900 white	Adhesive	x	x			XP,XR,MX	6wk std glass cap - don't touch MX lens
Dow Corning EA-4910 black	Adhesive	x	x			XP,XR,MX	6wk std glass cap - don't touch MX lens
Dow Corning EA-9189H	Adhesive	x	x			XP,XR,MX	6wk std glass cap - don't touch MX lens
Epichlorhydrin	Rubber/ Plastic seals			x			
Epoxy resin (Two component)	Sealants and Adhesives						To be tested
Ethanolamine		x					

Material	Type	OK In App	Outgas Tested	Issues Suspected	Issues Found	Tested LED(s)	Conditions
Ethylene acrylic	Rubber/ Plastic seals						
Ethylene propylene (EPDM) rubber	Rubber/ Plastic seals		x		x		
Fantastik brand cleaner	Cleaning agents	x	x			XRE	
Formaldehyde or butadiene (including Ashland PLIOBOND® adhesive)	Adhesive		x		x	XRE	
Formula 409 brand cleaner	Cleaning agents	x	x			XRE	
FP5202 UV cure adhesive (Everwide)	Adhesive		x		x		6wk std glass cap
Gasoline /solvent,	Solvent			x			
General lubricants	Manufacturing materials	x			x		
General surfactants	Manufacturing materials	x	x				
Glycol ethers (including Radio Shack® Precision Electronics Cleaner - dipropylene glycol monomethyl ether)	Solvent		x		x	XRE	
GM299	Adhesive		x		x		6wk std glass cap
Gorilla Glue	Adhesive		x		x	XRE	
Gorilla Glue	Adhesive		x		x	XP,XR,MX	6wk std glass cap
Graphite gaskets	Thermal compound	x	x				
Halogenated hydrocarbons (containing F, Cl, Br elements) /misc			x	x			
Hongxin704	Coating/Potting		x		x	XPE, XRE	Dry 72hrs
HT902	Coating/Potting	x	x			XPE, XRE	Dry 72hrs
HT906T	Coating/Potting		x		x	XPE, XRE	Dry 72hrs
Huitian 9311T	Coating/Potting	x	x			XPE, XRE	Wet/Dry 72 hrs
Huitian HT902	Coating/Potting		x		x	XPE, XRE	Wet/Dry 72 hrs
Huitian HT-932TP	Coating/Potting	x	x			XPE, XRE, CLP6B	Wet/Dry 72 hrs
Humiseal 1B51NS	Conformal Coating	x	x			XRE	
Humiseal 1B51NS	Coating/Potting	x	x			XP,XR,MX	6wk std glass cap
Humiseal 1B73	Conformal Coating	x	x			XRE	
Humiseal 1B73	Coating/Potting	x	x			XP,XR,MX	6wk std glass cap
Humiseal 1C49LV	Conformal Coating	x	x			XRE	
Humiseal 1C49LV	Coating/Potting	x	x			XP,XR,MX	6wk std glass cap
Humiseal 1H20AR1/S	Conformal Coating	x	x			XRE	
Humiseal 1H20AR1/S	Coating/Potting	x	x			XP,XR,MX	6wk std glass cap
Humiseal UV40	Conformal Coating	x	x			XRE	
Humiseal UV40	Coating/Potting	x	x			XP,XR,MX	6wk std glass cap
Hydrochloric acid /Acid	Acid			x			
HZ-706	Coating/Potting		x		x	CLP6B	Wet/Dry 72 hrs
Iso Elektra IsoPur K760	Coating/Potting	x	x			XRE	6wks Std. Plas. Cap.
Isophorone di-isocyanate				x			
Isopropyl alcohol (IPA)	Cleaning agents	x	x			XRE	
JX046 UV Cure Adhesive	Adhesive		x		x		6wk std glass cap
Karl Schupp PUR277 UV	Coating/Potting	x	x			XRE	6wks Std. Plas. Cap.

Material	Type	OK In App	Outgas Tested	Issues Suspected	Issues Found	Tested LED(s)	Conditions
Lard /oil	Oil/ lubricant			x			
LED seal	Conformal coating	x	x			XP,XR,MX	6wk std glass cap
Linseed oil /oil	Oil/ lubricant			x			
Liyao KY-1312	Coating/Potting	x	x			XPE, XRE	Dry 72hrs
Loctite 222	Adhesive		x		x		6wk std glass cap
Loctite 242 threadlocker	Adhesive		x		x	XP,XR,MX	6wk std glass cap
Loctite 3106	Adhesive		x		x		6wk std glass cap
Loctite 384 adhesive	Adhesive		x		x	XP,XR,MX	6wk std glass cap
Loctite 3873	Adhesive		x		x		6wk std glass cap
Loctite 498	Adhesive		x		x		6wk std glass cap
Loctite 542	Adhesive	x	x			XRE	6wks Std. Plas. Cap.
Loctite 7387	Adhesive		x		x		6wk std glass cap
Loctite 7387 activator	Adhesive		x		x	XP,XR,MX	6wk std glass cap
Loctite antiseize	Anti-seize material		x		x	XR,XP,MX	6wk std glass cap
Loctite Hysol 3421	Adhesive		x		x	XRE	6wks Std. Plas. Cap.
Loctite Hysol LC9481	Adhesive	x	x			XRE	6wks Std. Plas. Cap.
Loctite Hysol LC9489	Adhesive	x	x			XRE	6wks Std. Plas. Cap.
Loctite Sumo Glue	Adhesive		x		x	XRE	
Lord 6148S	Conductive adhesive	x	x			XR,XP,MX	6wk std glass cap
Lord MD-161	Conductive adhesive		x		x	XR,XP,MX	6wk std glass cap
Lord MG-133	Thermal grease	x	x			XR,XP,MX	6wk std glass cap
Lord MT-125	Thermal adhesive		x		x	XR,XP,MX	6wk std glass cap
Lord SC-309	Silicone gel	x	x			XR,XP,MX	6wk std glass cap
Lord TC-404	Thermal grease	X	x			XR,XP,MX	6wk std glass cap
Lysol brand disinfectant spray	Cleaning agents	x	x			XRE	
LZ6704	Coating/Potting	x	x			XPE, XRE	Dry 72hrs
Marine grade anti-seize	Anti-seize material		x		x	XR,XP,MX	6wk std glass cap
MCPCB (IMS)	PCB Manufacturing	x					
MEK (Methyl Ethyl Ketone) / solvent	Solvent			x			
Methyl acetate or ethyl acetate (i.e., nail polish remover)	Solvent		x		x	XRE	
Methylated Spirits	Manufacturing materials	x			x		
MIBK (Methyl Isobutyl Ketone) / solvent	Solvent			x			
Mineral Oil Lubricants	Manufacturing materials	x	x				
Mineral splits /solvent	Solvent			x			
Mingsheng MS-20-1	Coating/Potting		x		x	XPE, XRE	Wet/Dry 72 hrs
Neodecanoic acid glycidyl ester				x			
Nitric acid /Acid	Acid			x			
Non-silicon thermal grease	Thermal compound	x	x			XRE	
Nylon PA	Structural plastic	x					
Outgassing aromatic hydrocarbons (e.g., toluene, benzene, xylene)	Solvent		x		x	XRE	
Parabond transparent	Adhesive	x	x			XPE	6wk std glass cap

Material	Type	OK In App	Outgas Tested	Issues Suspected	Issues Found	Tested LED(s)	Conditions
Perfluoro elastomers	Rubber/ Plastic seals	x					
Permacol 5706	Adhesive	x	x			XPE	6wk std glass cap
Peters ELPEguard DSL1706 FLZ	Conformal coating	x	x			XR,XP,MX	6wk std glass cap
Peters ELPEguard SL1307 FLZ/2	Conformal coating	x	x			XR,XP,MX	6wk std glass cap
Peters ELPEguard SL1397	Conformal coating	x	x			XR,XP,MX	6wk std glass cap
Petroleum /oil	Oil/ lubricant			x			
Phenyl mercuric neodecanoate				x			
Pledge furniture spray	Cleaning agents	x	x			XRE	
Polycarbonate PC	Structural plastic	x					
Polyethylene	Rubber/ Plastic seals	x					
Polynorbornene rubber	Rubber/ Plastic seals			x			
Polypropylene PP	Structural plastic	x					
Polystyrene GPPS	Structural plastic	x					
Polysulphide rubber	Rubber/ Plastic seals			x			
Polyurethane foam with acrylic pressure sensitive adhesive	Adhesive T\tape		x	x			
Polyurethane rubber	Rubber/ Plastic seals			x			
Polyurethane Sealant/Adhesive	Sealants and Adhesives						To be tested
potassium hydroxide /alkali	Alkaline			x			
Premium copper anti-seize	Anti-seize material		x		x	XR,XP,MX	6wk std glass cap
Release Agents (Oil, Wax, Solvent and Water Based)	Manufacturing Materials	x	x		x		
RTV 3145	Adhesive	x	x				6wk std glass cap
Scrubbing Bubbles brand bathroom cleaner	Cleaning agents	x	x			XRE	
Shat-R-Shield	Coating/Potting	x	x			XP,XR,MX	6wk std glass cap
Shinemax UV cure	Adhesive		x		x		6wk std glass cap
Shinetsu x-832 and 350-3 two part optical coupler (silicone)	Adhesive	x	x				6wk std glass cap
Silicone (and fluorosilicone) rubber	Rubber/ Plastic seals	x					
Silicone encapsulent/Potting resins	Sealants and Adhesives	x	x		x		
Silicone grease	Manufacturing Materials	x					
Silicone oil /oil	Oil/ lubricant			x			
Sodium hydroxide /alkali	Alkaline			x			
Solder Flux Resin	PCB manufacturing		x		x		excessive flux resin is bad
Solder paste, reflowed	PCB manufacturing	x	x				
Solder resist	PCB manufacturing	x					
Specialty coating systems - parylene	Coating/Potting	x	x			XP,XR,MX	6wk std glass cap
Standard antiseize	anti-seize material		x		x	XR,XP,MX	6wk std glass cap
Standard copper anti-seize	anti-seize material		x		x	XR,XP,MX	6wk std glass cap
Star technologies 4050T	Adhesive	x	x				6wk std glass cap
Styrene butadiene rubber	Rubber/ Plastic seals			x			
Sulfuric acid /Acid	Acid			x			

Material	Type	OK In App	Outgas Tested	Issues Suspected	Issues Found	Tested LED(s)	Conditions
SX720W	Coating/Potting		x		x	MCE	Wet/Dry 72 hrs
TechSpray Turbo-Coat acrylic conformal coating (2108-P)	Coating/Potting	x	x			XP,XR,MX	6wk std glass cap
Terostat MS 931	Coating/Potting		x		x	XRE	6wks Std. Plas. Cap.
Tetracholorometane /solvent	Solvent			x			
Tetradecylamine				x			
Tetra-fluoroethylene/propylene	Rubber/ Plastic seals			x			
Thermal transfer grease (silicone based)	Thermal compound	x	x				
Thermal transfer tape (with or without adhesives)	Thermal compound	x	x				
Tilex brand mold & mildew remover	Cleaning agents	x	x			XRE	
Toluene /solvent	Solvent			x			
Toray silicone SE 9176 RTV	Adhesive	x	x				6wk std glass cap
Trimethylhexamethylene diamine				x			
Two component polyurethane adhesives	Sealants and adhesives						To be tested
UV acrylic adhesives	Sealants and adhesives	x			x		
Windex, Windex Outdoor & Windex Vinegar brand cleaners	Cleaning agents	x	x			XRE	
Xylene /solvent	Solvent			x			